

**White**

**Rose  
Maths**

Year 6

**Perimeter, Area & Volume**

Rosie and Dexter are drawing shapes with an area of  $30\text{cm}^2$



Dexter's shape

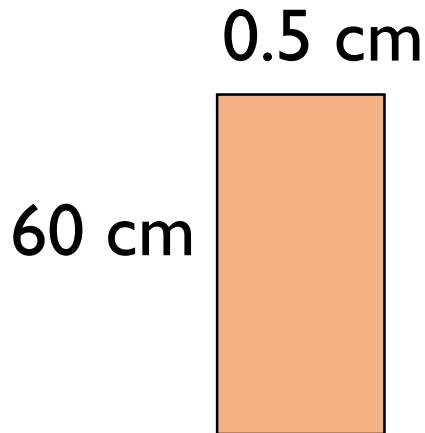

Rosie's shape

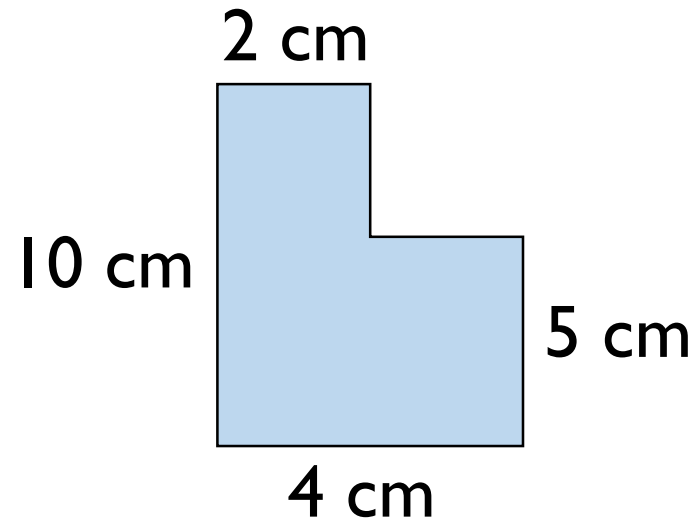

Who is correct?

Explain your reasoning.

Three children are given the same rectilinear shape to draw.

Amir says, “The smallest length is 2 cm.”

Alex says, “The area is less than  $30 \text{ cm}^2$ .”

Annie says, “The perimeter is 22 cm.”

What could the shape be?

How many possibilities can you find?

# Always, Sometimes, Never?

If the area of a rectangle is odd then all of the lengths are odd.

# True or False?

Two rectangles with the same perimeter can have different areas.

Explain your answer.

A farmer has 60 metres of perimeter fencing.

For every  $1 \text{ m}^2$  he can  
keep 1 chicken.



How can he arrange his fence so that the enclosed  
area gives him the greatest area?

Tommy has a  $8 \text{ cm} \times 2 \text{ cm}$  rectangle. He increases the length and width by 1 cm.

Length	Width	Area
8	2	
9	3	

He repeats with a  $4 \text{ cm} \times 6 \text{ cm}$  rectangle.

Length	Width	Area
4	6	

What do you notice happens to the areas?

Can you find any other examples that follow this pattern?

Are there any examples that do not follow the pattern?

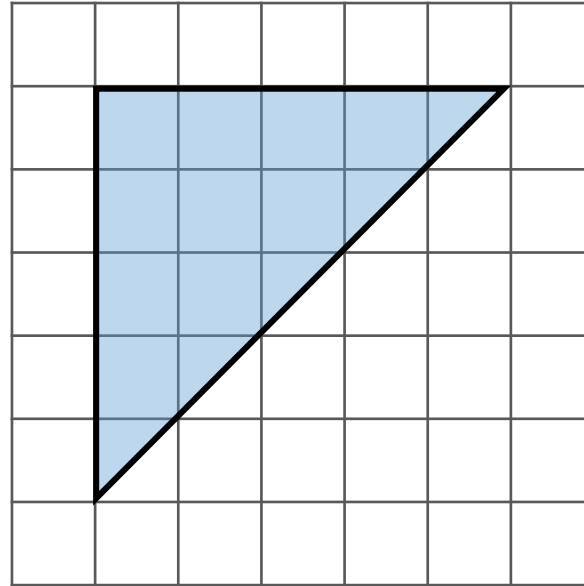

Mo says the area of this triangle is  $15\text{cm}^2$   
Is Mo correct? If not, explain his mistake.



Part of a triangle has been covered.

Estimate the area of the whole triangle.

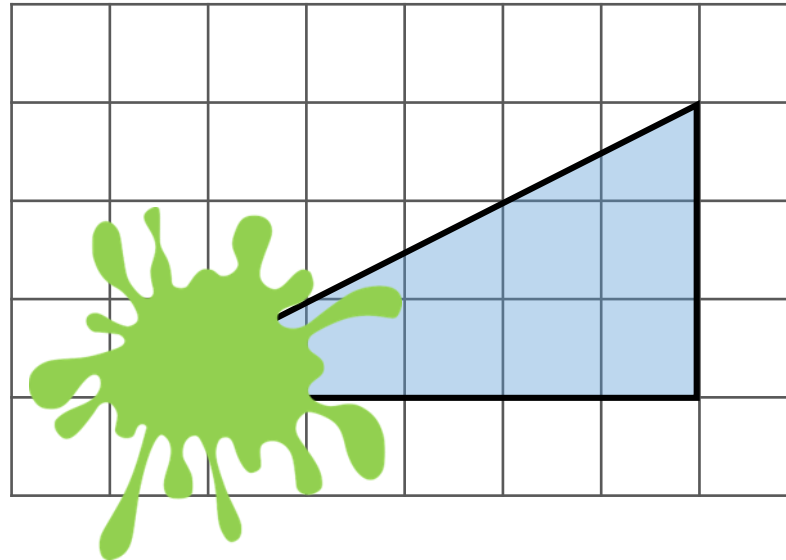

What is the same about these two triangles?  
What is different?

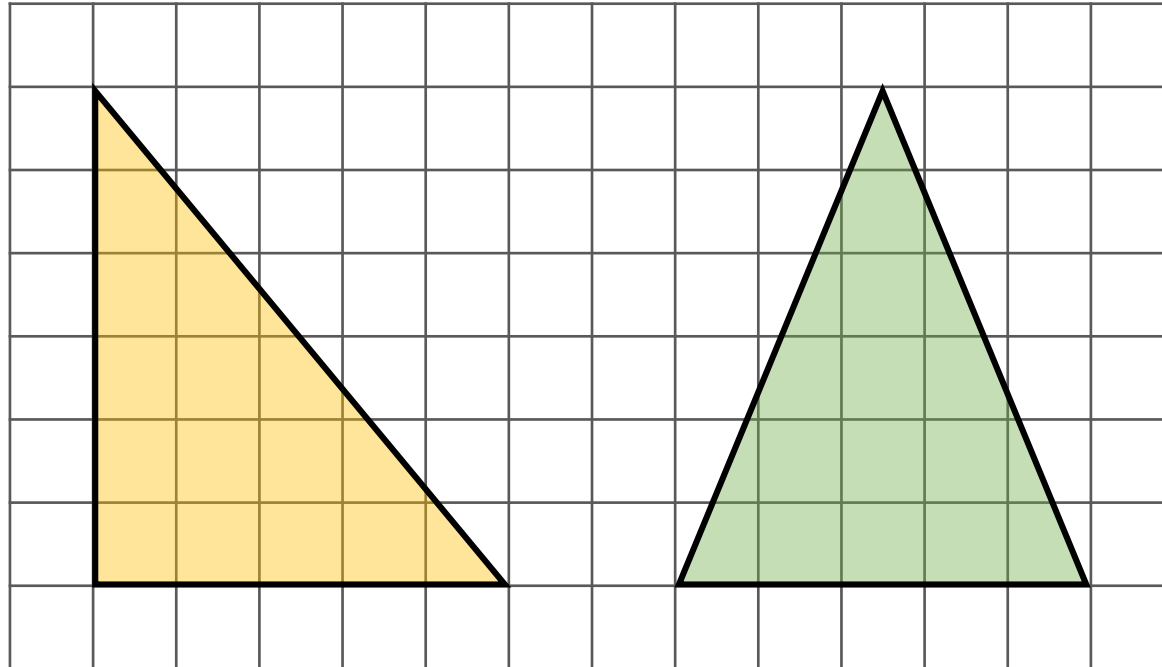

Can you create a different right angled triangle with the same area?

Annie is calculating the area of a right-angled triangle.



I only need to know the length of any two sides to calculate the area of a triangle.

Do you agree with Annie? Explain your answer.

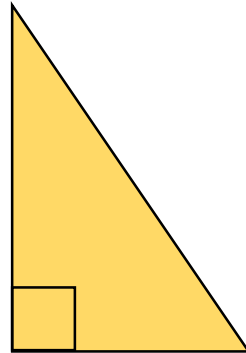

$$\text{Area} = 54 \text{ cm}^2$$

What could the length and the height of the triangle be?

How many different integer possibilities can you find?

Calculate the area of the shaded triangle.

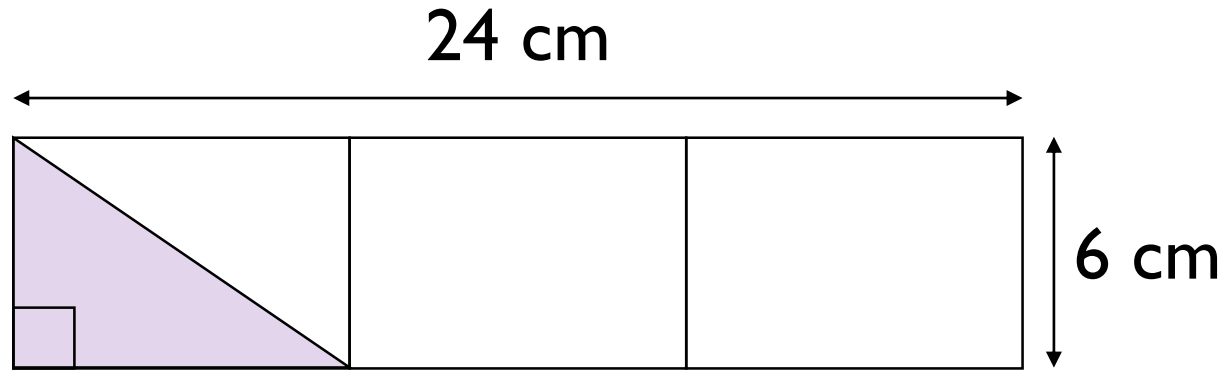

Mo says,



I got an answer of  
 $72 \text{ cm}^2$

Do you agree with Mo?

If not, can you spot his mistake?

Class 6 are calculating the area of this triangle.

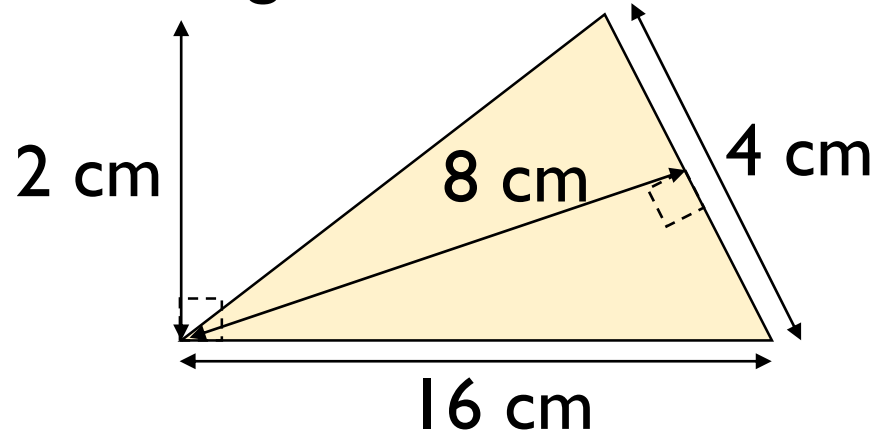

Here are some of their methods.

$$4 \times 8 \times 16 \times 2 \div 2$$

$$4 \times 8 \div 2$$

$$16 \times 2 \div 2$$

$$16 \times 4 \div 2$$

$$16 \times 8 \div 2$$

$$8 \times 1$$

Tick the correct methods.

Explain any mistakes.

The shape is made of three identical triangles.

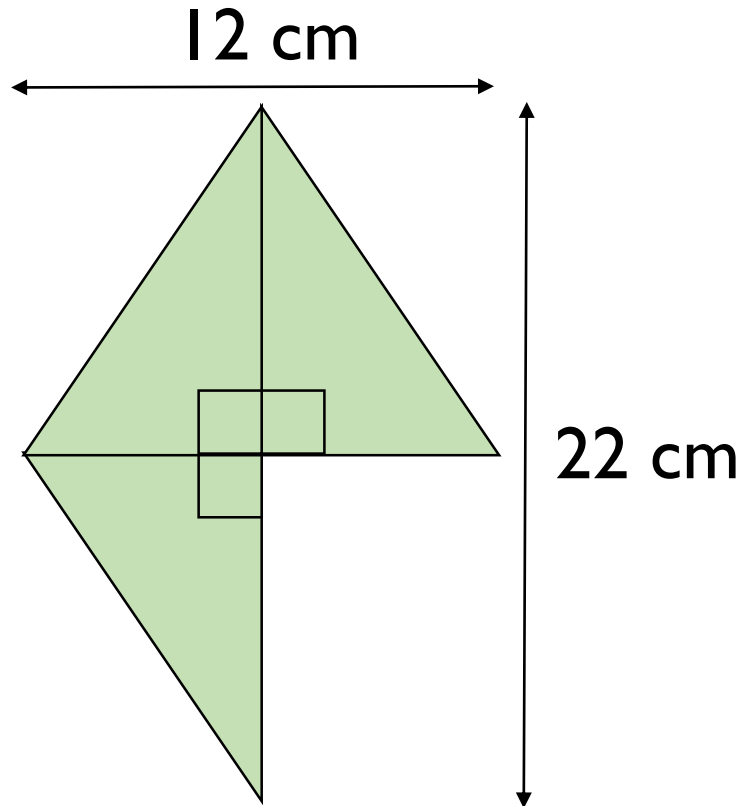

What is the area of the shape?

Teddy has drawn a parallelogram.

The area is greater than  $44 \text{ m}^2$  but less than  $48 \text{ m}^2$ .

What could the base length and the perpendicular height of Teddy's parallelogram be?



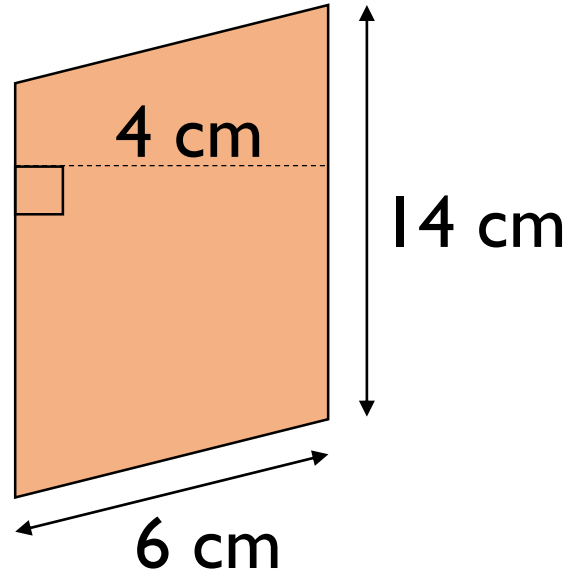

Dexter thinks the area of the parallelogram is  $84 \text{ cm}^2$ .

What mistake has Dexter made?

What is the correct area?

Dora and Eva are creating a mosaic.  
They are filling a sheet of paper this size.

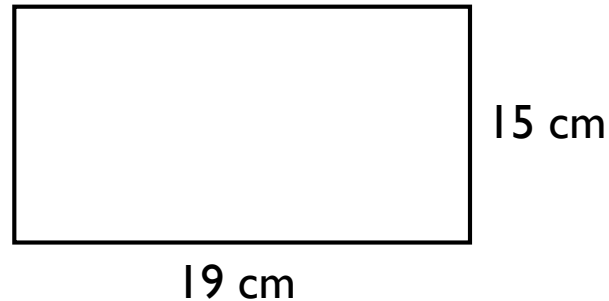

Dora is using tiles that are rectangular.

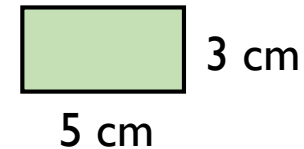

Eva's tiles are parallelograms.

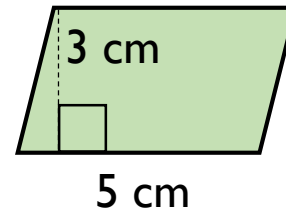

Dora thinks that she will use fewer tiles than Eva to fill the page because her tiles are bigger.  
Do you agree? Explain your answer.

Amir says he will need  $8 \text{ cm}^3$  to build this shape.

Dora says she will need  $10 \text{ cm}^3$ .

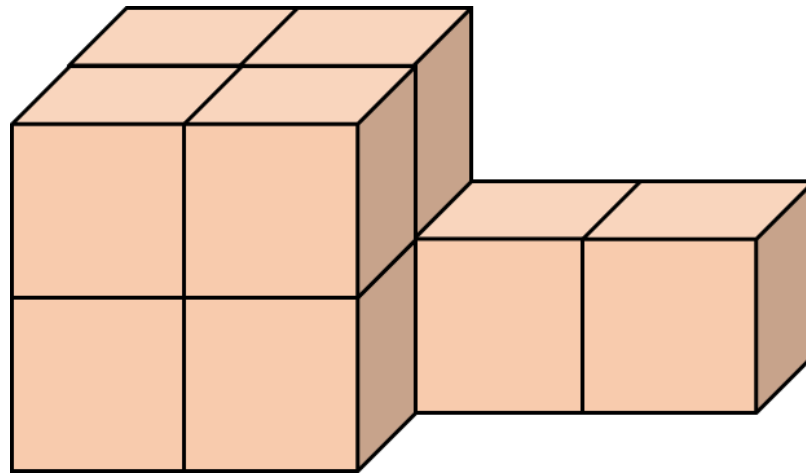

Who do you agree with?

Explain why.

Tommy is making cubes using multilink.  
He has 64 multilink cubes altogether.

How many different sized cubes could he make?

He says,



If I use all of my multilink to make 8 larger cubes, then each of these will be 2 by 2 by 2.

How many other combinations can Tommy make where he uses all the cubes?

Rosie says,



You can't calculate the volume of the cube because you don't know the width or the height.

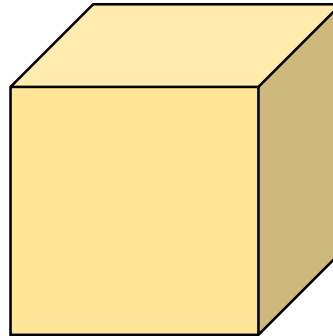

2 cm

Do you agree?

Explain why.

Calculate the volume of the shape.

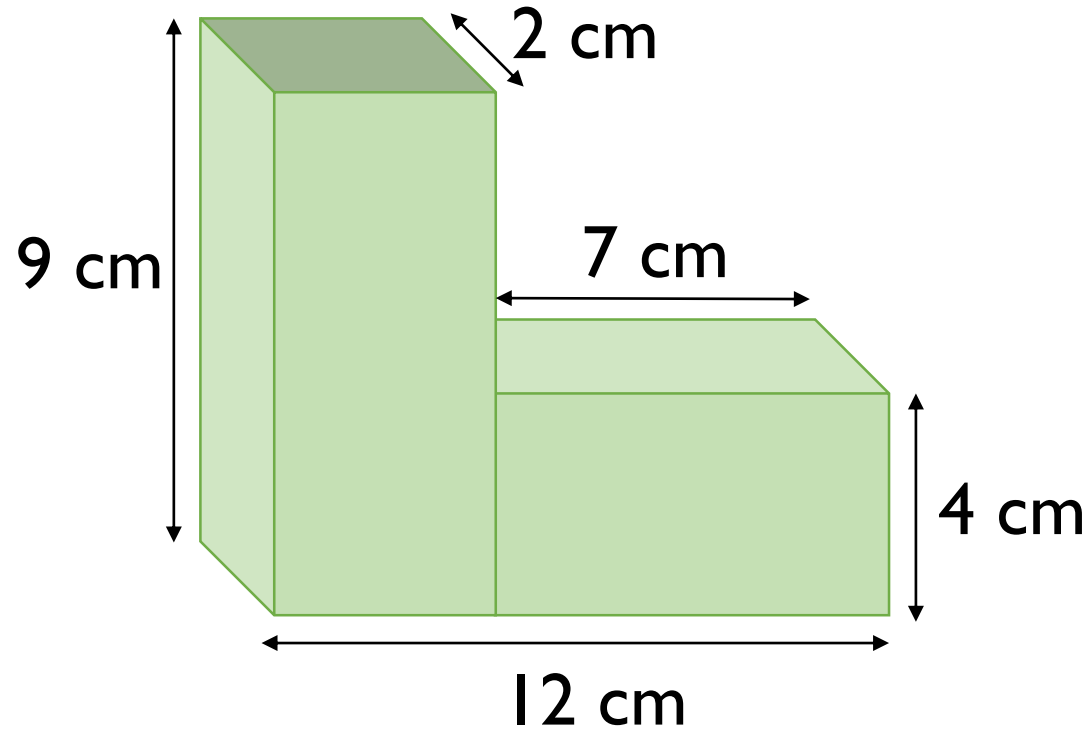

How many different ways can you make a cuboid with a volume of  $48 \text{ cm}^3$ ?

